

General Specifications:

- ✿ 20°F to 70°F Leaving Coolant Range
- ✿ 90 Gallon 304 Stainless Steel Evaporator Tank
- ✿ Tank Sight Glass, 15 PSI Relief Valve, and Air Vent
- ✿ Integrated Operating and Safety Controls
- ✿ Simple and Efficient Refrigeration Circuit
- ✿ Aluminum Structural Frame
- ✿ Weatherproof Mechanical and Electrical Sections
- ✿ Automatic Variable Speed Discharge Pressure Control
- ✿ Single Point Electrical Connection
- ✿ Stainless Steel Fan Shroud and Composite Prop

Model	Description	Flow GPM	Capacity @ 95°F Ambient (1,000's BTUH)			Pipe size	Electrical size	Shipping Weight
			35°F	45°F	55°F			
CF-20-A	Single Compressor	60	183	227	278	2"	2"	2,400 lbs.
CF-20-A-D	Dual Compressor	60	177	219	266	2"	2"	2,500 lbs.

Integrated Available Options

CATALOG	DESCRIPTION
CVF02001	Locking Casters
CVF02002	Super Low Ambient Kit
CVF02003	High Ambient Kit
CVF02004	Stainless Steel Panels/Hardware
CVF02005	Heresite Coated Condenser Coils
CVF02006	Disconnect Switch (Door Mounted)
CVF02007	VPM Voltage Phase Monitor
CVF02008	6 Point Digital Temp Display
CVF02009	Refrigerant Gauges (per circuit)
CVF02011	Tank Level Alarm
CVF02012	Tank Auto-Fill
CVF02014	Remote Operating Panel
CVF02015	Tank Fill Pressure Reducing Valve
CVF02016	Flow Switch (paddle)
CVF02018	System Pump Pressure Bypass Valve
CVF02019	System Pump VFD
CVF02020	Vibration Isolation Mounts
CVF02021	Water Cooled Condensers Mod Valve

Safety and Operating Controls

- ✿ Temperature and pressure gauge panel
- ✿ High and low refrigerant pressure lockouts
- ✿ Simple electronic temperature controls
- ✿ Two stages with dual compressor system
- ✿ Suction pressure operating control
- ✿ Discharge pressure control for condenser fans
- ✿ Contactors, motor starters, and overloads

Refrigeration Circuit

- ✿ 20 ton nominal semi-hermetic compressor or two 10 ton scroll compressors
- ✿ Independent refrigeration circuit per compressor
- ✿ Remote air-cooled condenser copper/aluminum
- ✿ Stainless steel brazed plate evaporator
- ✿ Thermostatic expansion valve
- ✿ Liquid-line filter dryer
- ✿ Refrigerant sight glass
- ✿ Suction and discharge service access valves

Chiller Solutions LLC

101 Alexander Ave., Pompton Plains, NJ 07444
(800) 468-3826, (973) 835-3222 fax
www.edwards-eng.com

Engineering Specifications

All data subject to change without notice
Chiller Solutions LLC 2005, all rights reserved

Physical Data	CF-20-A
Unit Dimensions	84"L x 39" W x 90" H
Dry Weight	2,200 lbs.
Operating Weight	2,850 lbs.
Oil Weight	27.6 pt
Refrigerant Weight	25 lbs.
Piping Connections	2" FPT
Electrical Connections	2"
Reservoir Capacity	90 Gallons
Condenser CFM	14,000 CFM
Nominal Pump Design	60 GPM @ 100' Head

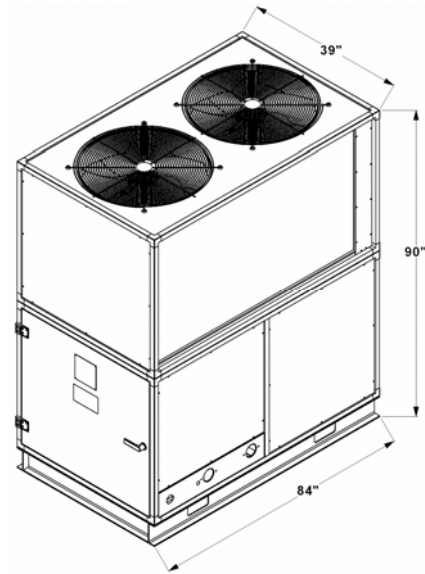

Electrical Data															
Single Comp.	Volts	Phase	HZ	Compressor (Each)			Fan (Each)			System Pump			Total Unit	MFS	MCA
				Qty	HP	RLA	Qty	HP	FLA	Qty	HP	FLA	FLA		
	230	3	60	1	20	59.0	2	1	5.0	1	3	8.0	77.0	150.8	91.8
	460	3	60	1	20	29.5	2	1	2.5	1	3	4.0	38.5	75.4	45.9
Dual Comp.	230	3	60	2	10	28.6	2	1	5.0	1	3	8.0	75.2	111.0	82.4
	460	3	60	2	10	14.3	2	1	2.5	1	3	4.0	37.6	55.5	41.2

NOTES:

1. Transformer reflects all power used in control circuit.
2. FLA is at 45° LCT and 95° Ambient Temperature
3. For 208V, multiply 460v values by 2.21

Performance Data		CF-20-A-D				
		Ambient Temperature				
LCT °F	75°	85°	95°	105°	115°	
60°	323.4	308.0	291.8	274.8	257.0	
55°	295.4	281.2	266.0	250.0	233.4	
50°	269.0	255.6	241.6	226.6	211.2	
45°	244.8	232.4	219.3	205.3	190.9	
40°	220.6	209.2	197.0	184.0	170.6	
35°	199.4	188.8	177.5	165.4	152.9	
30°	178.2	168.4	158.0	146.8	135.2	
25°	160.0	150.9	141.2	127.8	-	
20°	141.8	133.4	124.4	108.8	-	

* Net capacities not including BTUH's from system pump
 ** Capacity in 1,000 BTUH's with water only
 *** LCT =Leaving Coolant Temperature

System Pump Performance Curve (Nominal)

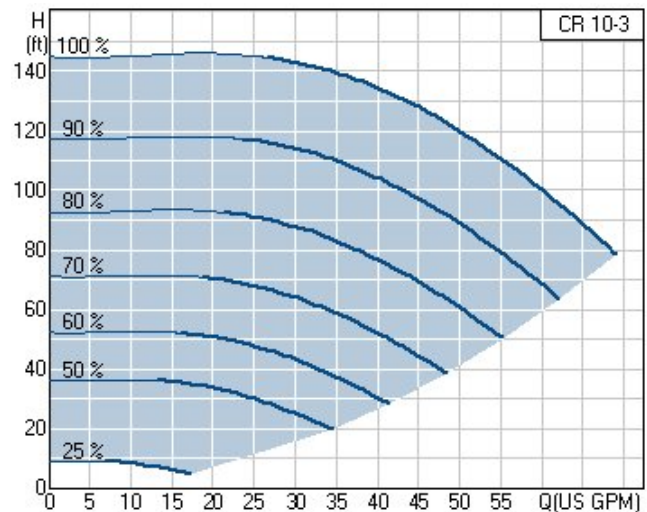

Chiller Solutions LLC

101 Alexander Ave., Pompton Plains, NJ 07444
 (800) 468-3826, (973) 835-3222 fax
 www.edwards-eng.com

Engineering Specifications

All data subject to change without notice
 Chiller Solutions LLC 2005, all rights reserved